

THE NEXT LEVEL V-BELT RANGE

Fenner Ultra PLUS

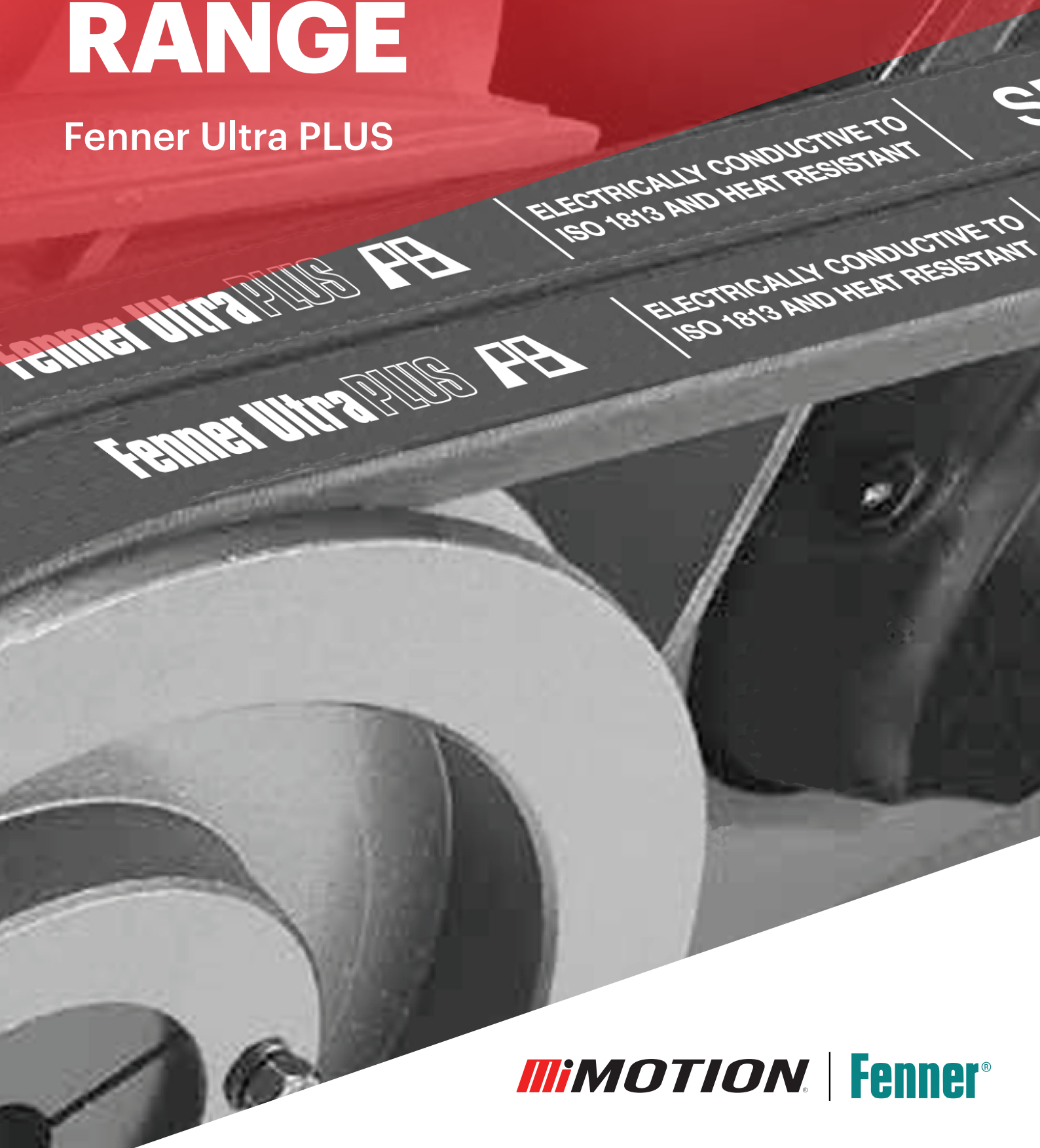

The
NEXT LEVEL
V-Belt Range

Fenner® Ultra PLUS

APPLICATIONS

The Fenner® Ultra PLUS narrow-section V-belt is suitable for many applications in general mechanical engineering where space-saving heavy-duty drives are involved, e.g. exhaust-air extraction systems, mills, mixers and pumps. Other application fields include Sawmills, Shredders and Layshaft for heavy duty conveyors.

FEATURES

- Moderately oil-resistant
- Suitable for tropical climates
- Unaffected by dust
- Temperature-resistant from -55°C to +70°C
- Electrically conductive to ISO 1813
- Matched-set L=L (from 1,000mm)

Fabric Jacket

Natural Rubber

Polyester Tension Member

Double Canvas Wrap

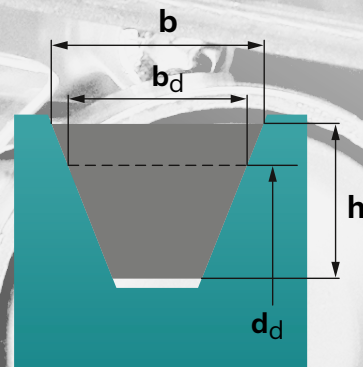

Wrapped narrow-section V-belts to DIN 7753 for demanding drives in every mechanical engineering field

SECTIONS		SPZ/3V/9N	SPA	SPB/5V/15N1	19	SPC	8V/25N
Top Belt Width	b (mm)	9.7	12.7	16.3	19	22	25.4
Belt Height	h (mm)	8	10	13	15.7	18	23.1
Pitch Width	b_d (mm)	8.5	11	14	15	19	25.4
Length Ranges	L_d (mm)	512-3750	732-6000	1250-9000	1400-4475	2000-16500	4318-12700
Minimum Pulley Diameter	d_d (mm)	63	90	140	224	224	315

COMPARISON

FENNER CLASSIC TO WEDGE V-BELTS

In most cases a narrow-section V-belt can replace a classical-section V-belt without a problem. Up to 33% higher belt speeds can be achieved by comparison.

The larger surface area means that the Fenner Ultra Plus narrow-section V-belt offers better heat dissipation and potential cost savings of up to 40% compared with classical section wrapped V-belts.

DISCOVER THE EXTENDED V-BELT RANGE

	STANDARD	NEXT LEVEL
WEDGE V-BELTS SPZ,SPA, SPB & SPC	Fenner Power PLUS	Fenner Ultra PLUS
CLASSIC V-BELTS Z,A,B,C,D & E	Fenner Classic	Fenner Classic Ultra PLUS

- Fenner Ultra PLUS – Electrically conductive to ISO 1813
- Fenner Classic Ultra PLUS – Electrically conductive to ISO 1813

	Power PLUS (STANDARD)	Ultra PLUS (NEXT LEVEL)
Wrap	Single canvas wrap	Double canvas wrap providing extended service life
Cords	Quality polyester cords	Enhanced quality polyester cords for improved performance and life
Power Range	Standard power range	Improved power range
Use	Excellent general purpose V-Belt	Top selling V-Belt in Europe

COMPLETE DRIVE SOLUTIONS

Fenner’s cutting-edge solutions with Motion’s strong distribution capabilities and technical support, means customers benefit from a comprehensive package that goes beyond mere product supply. This collaboration ensures that customers receive tailored solutions that address their unique challenges, ultimately boosting their productivity and success.



Fenner has been a leading name in power transmission for over 150 years and generations of professional engineers have placed their trust in Fenner products.

- Pulleys
- Taper Locks
- Jaw Shaft Couplings
- Fenaflex™ Tyre Coupling
- HRC Couplings
- Worm Reducers
- Sprockets
- Chain



B10-029 8/23

iMOTION

Delivering a world-class customer-first approach providing excellence and expertise in industrial products, solutions and services.

iMOTION
FLUID POWER SOLUTIONS

Specialists in Fluid Power Solutions tailored to keep your equipment moving.

iMOTION
ENGINEERING & SERVICES

Specialist design and engineering, manufacturing, repair and maintenance services.

Anytime. Anywhere.
Always Here.™

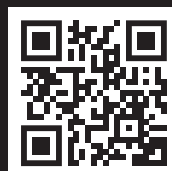

Find a location near you!

Scan the QR Code to find out more
or visit Motion.com.au