

FENNER GRID COUPLING

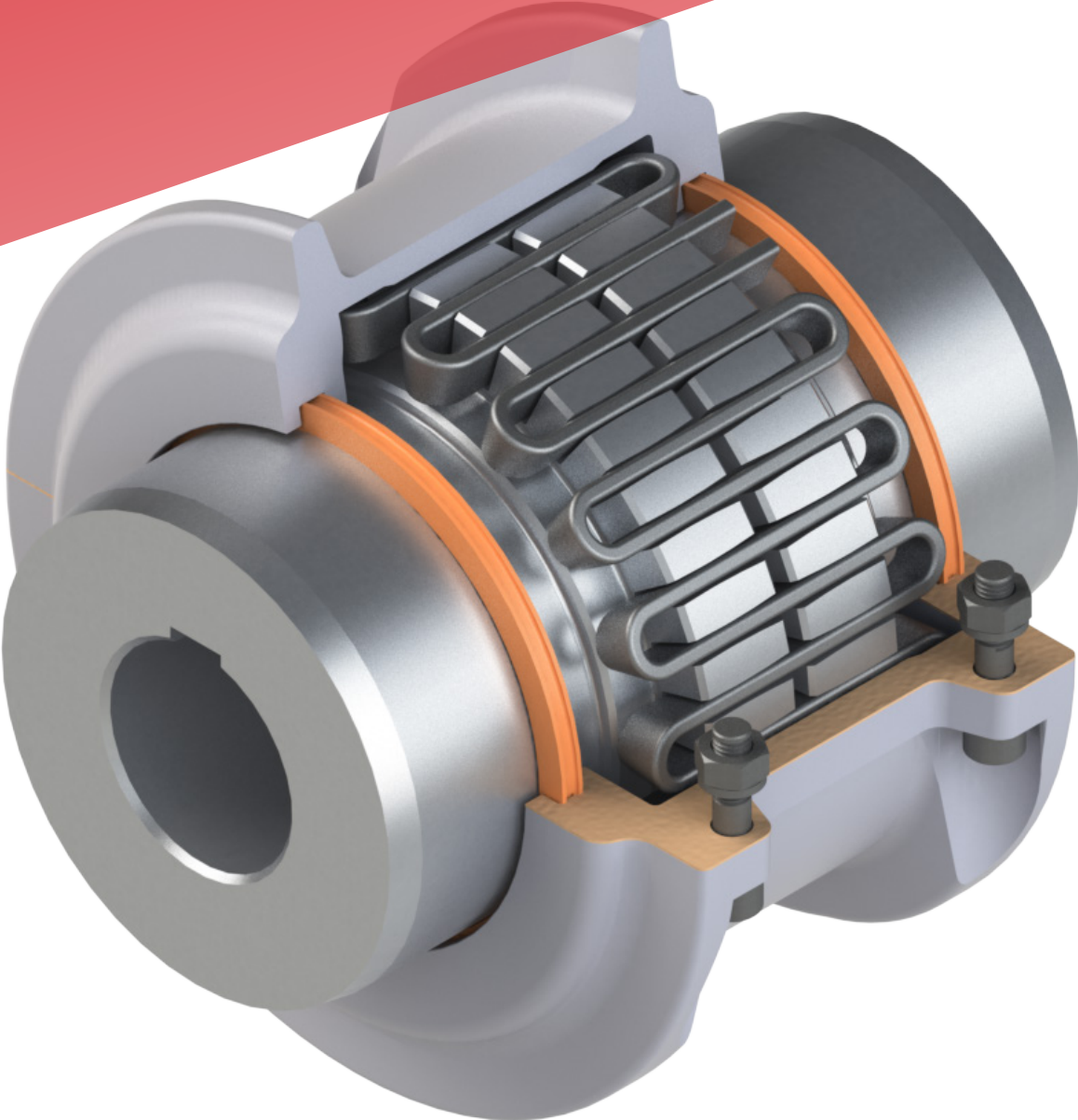

WHO WE ARE.

Motion delivers a world-class customer-first approach to everything we do. This has firmly established our business as the leader in the market, providing excellence and expertise in industrial products, solutions and services.

For more than 100 years we have been a feature in the Australian industrial landscape giving customers unmatched products and service through an integrated network of branches, workshops and service centres.

We have an ongoing commitment to invest in our people, facilities, IT and systems to ensure we can continue to offer a broad ranging and premium level of engineering design, servicing and turnkey projects to our customers across Australia.

We are committed and proud to keep our customers in motion, every day of the year.

“ WE KEEP THE WORLD MOVING ”



CONTENTS

Description	4
Protection & Standard Coupling Selection	5
Formula Selection	6
Service Factors (by Application & Industry)	7
Service Factors for Combustion Engines	8-10
T10 Type (Close Coupled - Split Cover)	11
T10 Type (Close Coupled - Split cover - Large)	12
T20 Type (Close coupled - Vertical Steel Cover)	13
T31 Type (Full Spacer)	14
T35 Type (Half Spacer)	15
T50 Type (Floating Shaft – Steel Cover)	16
T63 Type (Disc Brake)	17
KBW Type (Drum Brake)	18
T10 / G82 Type (Floating Shaft)	19-20
Installation	20
Annual Maintenance	20
Vibration / Shock and Lubrication	21
Alignment Data	23
Misalignment Capacity and Puller Holes	23

All the items included are aftermarket products for the replacement of existing parts.
Motion Australia is not an original equipment manufacturer of these products.

INTRODUCTION

Fenner® Grid Couplings are shaft-to-shaft couplings that are of compact size yet can handle torque capacity due to their high strength hardened alloy steel construction.

The tapered grids are designed with a trapezoidal cross section and are tempered for spring hardness. Through a high-precision operation called shot peening, the surface molecules are compressed by high-velocity steel micro beads.

The compression of the molecules results in dramatic increase in strength rating and provides

reserve strength for a longer part life.

The tapered grids are accessible through the unit's removable cover. It is extremely easy to fit the trapezoidal grids into the slots of the hub, compared to fitting rectangular grids. There is no need for the equipment to be moved (hence no downtime) so that couplings can be installed.

Due to their compact size, the tapered grids can simply be placed directly in the slots of the hub. The practical split cover can be placed using standard tools.

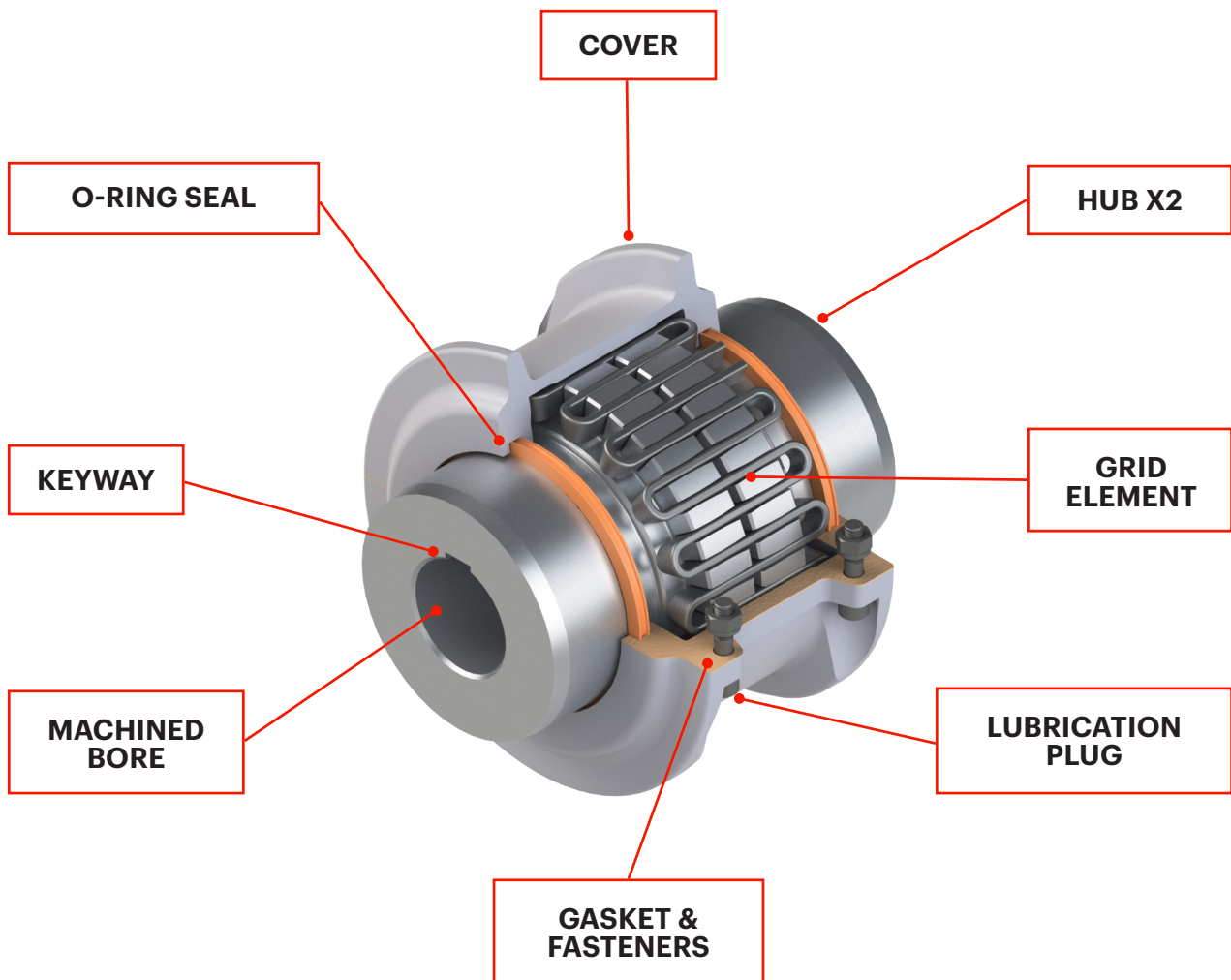

DESCRIPTION

PROTECTION AGAINST SHAFT MISALIGNMENT

The tapered grids are free to rock, pivot, and float within the hub teeth. This provides generous capacity for misalignment without producing the detrimental axial loads on the bearings that are often created when couplings are misaligned.

PROTECTION AGAINST SHOCK & VIBRATORY LOADS

This coupling is able to deflect torsionally when subjected to normal shock or vibratory loads, so they are able to handle changing load conditions. The system truly is a shock absorber for rotary motion, relying on the predictable resilience of the grid for torsional flexibility. The tapered grids "tune" the drive system. Due to their spring hardness, the grids absorb impact by spreading the impact energy over time. The grids can also damp vibration and reduce the peak or shock loads experienced by the rest of the system.

STANDARD COUPLING SELECTION

The Standard Selection may be used for engine driven, motor, or turbine applications. The information required are application or equipment type (motor to pump, reducer to conveyor, etc), shaft diameters (mm), gaps

1. Rating. Determine System Torque as calculated below:

$$\text{Torque (Nm)} = \frac{\text{kW} \times 9,550}{\text{rpm}}$$

$$\text{Torque (Kg.m)} = \frac{\text{kW} \times 974}{\text{rpm}}$$

2. Service Factor: Determine appropriate service factor.

3. Minimum Coupling Rating: Determine the required minimum coupling rating. (Minimum Coupling Rating = Service Factor x Torque (Nm)).

4. Type: Select the appropriate coupling type.

5. Size: Trace the Torque column to find the value that is equal or greater than value from Step 3.

6. Check: Check speed (rpm), bore, gap and dimensions.

FORMULA SELECTION

The Standard Selection should be used for most coupling selections. The Formula Selection procedure below should be used for high peak loads and brake applications (brake disc or brake wheel is an integral part of coupling). Using the Formula Selection and providing system peak torque and frequency, duty cycle, and brake torque rating will allow for a more refined selection.

High Peak Loads: Use formula A or B for applications which involve motors with higher-than-normal torque characteristics. Applications should also be those with intermittent operations, including shock loading, inertia effects due to starting and stopping, system-induced repetitive high peak torques. System Peak Torque is the maximum torque that can exist in the system. Select a coupling with a Torque Rating equal or greater than the Selection.

A. Non-Reversing High Peak Torque:

Selection torque (Nm) = System Peak Torque

or

System Torque (Nm) = System Peak kW x 9550 / rpm

B. Reversing High Peak Torque:

Selection Torque (Nm) = 2 x System Peak Torque

or

System Torque (Nm) = (2 x System Peak kW) x 9550 / rpm

2. Brake Applications: If the torque rating of the brake exceeds the motor torque, use brake rating as below:

Selection Torque (Nm) = Brake Torque Rating x Service Factor



SERVICE FACTORS FOR OPERATION OF DRIVE SYSTEM (BY APPLICATION)

AERATOR	2	Welder Load	2
AGITATORS		HAMMERMILL	1.75
Vertical and Horizontal Screw, Propeller, Paddle	1	LAUNDRY WASHER or TUMBLER	2
BARGE HAUL PULLER	1.5	LINE SHAFTS	
BLOWERS		Any Processing Machinery	1.5
Centrifugal	1	MACHINE TOOLS	
Lobe or Vane	1.25	Auxiliary and Traverse Drive	1
CAR DUMPERS	2.5	Bending Roll, Notching Press, Punch Press,	1.75
CAR PULLERS	1.5	Planer, Plate Reversing	1.5
CLARIFIER or CLASSIFIER	1	Main Drive	1.5
COMPRESSORS		METAL FORMING MACHINES	
Centrifugal	1	Continuous Caster	1.75
Rotary, Lobe or Vane	1.25	Draw Bench Carriage and Main Drive	2
Rotary, Screw	1	Extruder	2
Flywheel Compressor		Farming Machine and Forming Mills	2
1 Cylinder, single acting	3	Slitters	1
1 Cylinder, double acting	3	Wire Drawing or Flattening	1.75
2 Cylinders, single acting	3	Wire Winder	1.5
2 Cylinders, double acting	3	Coilers and Uncoilers	1.5
3 Cylinders, single acting	3	MIXERS	
3 Cylinders, double acting	2	Concrete	1.75
4 or more cylinders, single acting	1.75	Muller	1.5
4 or more cylinders, double acting	1.75	PRESS, PRINTING	1.5
CONVEYORS		PUG MILL	1.75
Apron, Assembly, Belt, Chain, Flight, Screw	1	PULVERIZERS	
Bucket	1.25	Hammermill and Hog	1.75
Live Roll, Shaker and Reciprocating	3	Roller	1.5
CRANES and HOIST		PUMPS	
Main Hoist	1.75	Boiler Feed	1.5
Skip Hoist	1.75	Centrifugal-Constant Speed	1
Slope	1.5	Frequent Speed Changes under Load	1.25
Bridge, Travel or Trolley	1.75	Descaling with accumulators	1.25
DYNAMOMETER	1	Gear, Rotary, or Vane	1.25
ELEVATORS		Reciprocating, Plunger Piston	
Bucket, Centrifugal Discharge	1.25	1 Cylinder, single or double acting	3
Gravity Discharge	1.25	2 Cylinders, single acting	2
EXCITER, GENERATOR	1	2 Cylinders, double acting	1.75
EXTRUDER, PLASTIC	1.5	3 or more cylinders	1.5
FANS		Screw Pump, Progressing Cavity	1.25
Centrifugal	1	Vacuum Pump	1.25
Cooling Tower	2	SCREENS	
Forced Draft-Across the Line start	1.5	Air Washing	1
Forced Draft Motor driven thru fluid or electric clutch	1	Grizzly	2
Gas Recirculating	1.5	Rotary Coal or Sand	1.5
Induced Draft with damper control or blade cleaner	1.25	Vibrating	2.5
Induced Draft without controls	2	Water	1
FEEDERS		STEERING GEAR	1
Apron, Belt, Disc, Screw	1	STOKER	1
Reciprocating	2.5	TIRE SHREDDER	1.5
GENERATORS		TUMBLING BARREL	1.75
Even Load	1	WINCH, MANEUVERING	
Hoist or Railway Service	1.5	Dredge, Marine	1.5
Welder Load	2	WINDLASS	1.5
Hoist or Railway Service	1.5	WOODWORKING MACHINERY	1

SERVICE FACTORS FOR OPERATION OF DRIVE SYSTEM (BY INDUSTRY)

AGGREGATE PROCESSING, CEMENT, MINING KILNS, TUBE & ROD MILLS	2	Drawbench	2
	1.75	Feed Rolls-Blooming Mills	2
Direct or on L.S. shaft of Reducer, with final drive Machined Spur Gears	2.5	Furnace Pushers	2
Single Helical or Herringbone Gears	1.75	Hot and Cold Saws	3
Crushers, Ore or Stone	2	Ingot Cars	
Dryer, Rotary	1.75	Manipulators	3
Grizzly	1.75	Mill Tables	1
Hammermill or Hog		Roughing Breakdown Mills	3
Tumbling Mill or Barrel	1	Hot Bed or Transfer, non-reversing	2
BREWING and DISTILLING	1	Runout, reversing	1.75
Bottle and Can Filling Machines	1.25	Runout, non-reversing, non-plugging	2
Brew Kettle	1.5	Reel Drives	
Cookers, Continuous Duty	1.25	Screw down	3
Lauter Tub	1.75	Seamless Tube Mills	2
Mash Tub		Piercer	2
Scale Hopper, Frequent Peaks	1.75	Thrust Block	2
CLAY WORKING INDUSTRY		Tube Conveyor Rolls	2
Brick Press, Briquette Machine, Clay Working Machine, Pug Mill	1.75	Reeler	3
DREDGES	1.25	Kick Out	
Cable Reel	2	Sideguards	
Conveyors	1.5	Slitters, Steel Mill only	1.75
Cutter head, Jig Drive	1.5	Lift	1
Manoeuvring Winch	1.75	Travel	2
Pumps (Uniform load)	1.5	Straighteners	2
Screen Drive, Stacker		Unscramblers (Billet Bundle Busters)	2
Utility Winch	1.75	Wire Drawing Machinery	1.75
FOOD INDUSTRY	1	OIL INDUSTRY	
Beet Slicer	1.25	Chiller	1.25
Botting, Can Filling Machine	1	Oilwell Pumping (not over 150% peak torque)	2
Cereal Cooker		Paraffin Filter Press	1.5
Dough Mixer, Meat Grinder	1.5	Rotary Kiln	2
LUMBER	1	PAPER MILLS	
Band Resaw	2	Barker Auxiliary, Hydraulic	2
Circular Resaw, Cut-off	2	Barker, Mechanical	2
Edger, Head Rig, Hog	1.75	Barking Drum	
Log Haul	1	L.S. shaft of reducer with final drive-Helical or Herringbone Gear	2
Planer	2	Machined Spur Gear	2.5
Rolls, non-reversing	1.25	Cast Tooth Spur Gear	3
Rolls, Reversing	1.75	Beater & Pulper	1.75
Sawdust Conveyor	1.5	Bleachers, Coaters	1
Slab Conveyor	1.75	Calendar & Super calendar	1.75
Sorting Table		Chipper	2.5
Trimmer	1.5	Converting Machine	1.25
METAL ROLLING MILLS	2	Couch	1.75
Coilers (Up or Down) Cold Mills only		Cutter, Felt Whipper	2
Coilers (Up or Down) Hot Mills only	2.5	Dryer	1.75
Coke Plants	2	Cylinder	1.75
Pusher Ram Drive	3	Felt Stretcher	1.25
Door Opener	1.75	Fourdrinier	1.75
Pusher or Larry Car Traction Drive	1.5	Jordan	2
Continuous Caster	2	Log Haul	2
Colling Beds	3	Line Shaft	1.5
		Press	1.75
		Pulp Grinder	1.75
		Reel, Rewinder, Winder	1.5
		Stock Chest, Washer, Thickener	1.5

SERVICE FACTORS FOR OPERATION OF DRIVE SYSTEM (BY INDUSTRY)

Stock Pumps, Centrifugal	
Constant Speed	1
Frequent Speed Changes Under load	1.25
Suction Roll	1.75
Vacuum Pumps	1.25
RUBBER INDUSTRY	
Calendar and Super Calendar	2
Cracker, Plasticator	2.5
Extruder	1.75
Intensive or Banbury Mixer	2.5
Mixing Mill, Refiner or Sheeter	
One or two in line	2.5
Three or four in line	2
Five or more in line	1.75
Tire Building Machine	2.5
Tire & Tube Press Opener (Peak Torque)	1
Tuber, Strainer, Pelletizer	1.75
Warming Mill - One or two Mills in line	2
Warming Mill - Three or more Mills in line	1.75
Washer	2.5
SEWAGE DISPOSAL EQUIPMENT	
Bar Screen, Chemical feeders, Collectors,	
Dewatering Screen, Grit Collector	
SUGAR INDUSTRY	
Cane Carrier & Leveller	1.75
Cane Knife & Crusher	2
Mill Stands, Turbine Driver with all Helical or Herringbone, or Spur Gears with any Prime Mover	1.75
TEXTILE INDUSTRY	
Batcher	1.25
Calendar, Card Machine	1.5
Cloth Finishing Machine	1.5
Dry Can, Loom	1.5
Dyeing Machinery	1.25
Mangle, Napper, Soaper	1.25
Spinner, Tenter Frame, Winder	1.5

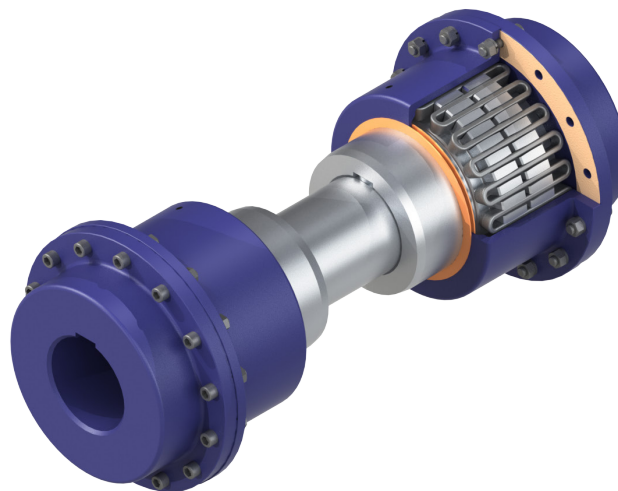







SERVICE FACTORS FOR COMBUSTION ENGINES

Service Factors for engine drives are required for applications where good flywheel regulation prevents torque fluctuations greater than $\pm 20\%$. For drives where torque fluctuations are greater or where the operation is near a serious critical or torsional vibration, a mass elastic study is necessary.

Number of Cylinders	4 of 5					6 or more				
Service of Factor	1.5	1.75	2	2.25	2.5	1.5	1.75	2	2.25	2.5
Engine Service Factor	2.5	2.75	3	3.35	3.5	2.5	2.75	3	3.25	3.5

To use Engine Drive Service Factors, first determine application Service Factor from page 8-10. When Service Factor is greater than 2.0, or where 1, 2 or 3 cylinder engines are involved, refer complete application details to Motion for engineering review.

Service Factors are a guide, based on experience, of the ratio between coupling catalogue rating and system characteristics. The system characteristics are best measured with a torque meter.

Torque Demands Driven Machine	Typical applications for Driven Equipment	Typical Service Factor
	Constant torque such as Centrifugal Pumps, Blowers and Compressors	1
	Continuous duty with some torque variations including Plastic Extruders, Forced Draft Fans	1.5
	Light shock loads from Metal Extruders, Cooling Towers, Cane Knife, Log Haul	2
	Moderate shock loading as expected from a Car Dumper, Stone Crusher, Vibrating Screen	2.5
	Heavy shock load with some negative torques from Roughing Mills, Reciprocating Pumps, Compressors, Reversing, Runout Tables	3
	Applications like Reciprocating Compressors with frequent torque reversals, which do not necessarily cause reverse rotations.	Refer to Motion

T10 TYPE (CLOSE COUPLED – SPLIT COVER)

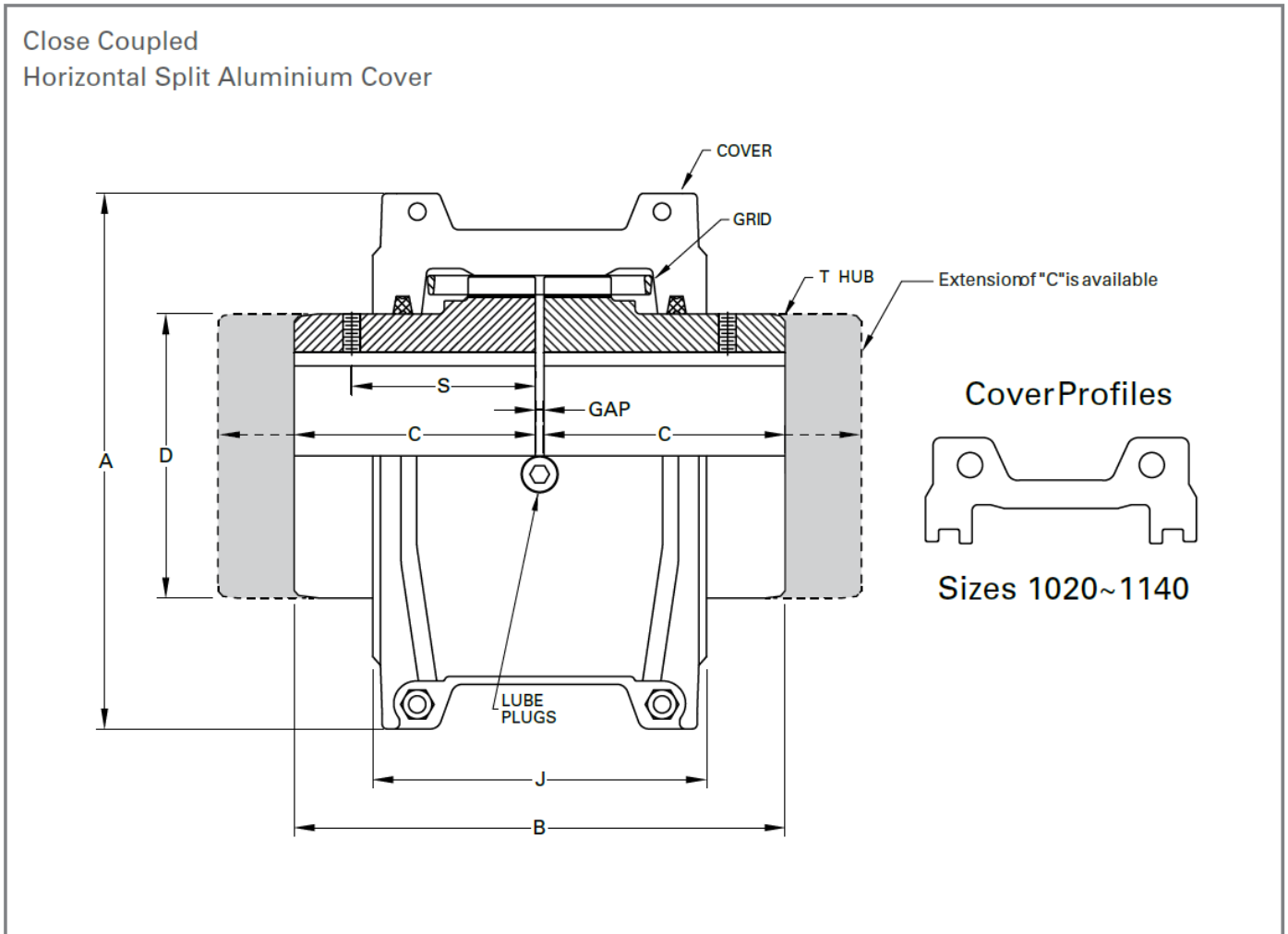

Size	Torque Rating (Nm)	Allow Speed RPM	Max Bore (mm)	Min Bore (mm)	Cplg Weight (Kg)	Lube Weight (Kg)	Dimensions (Millimeters)						
							A	B	C	D	J	S	GAP
1020	52	4,500	28	13	1.92	0.0272	101.0	98.2	47.6	39.7	67.8	39.1	3
1030	149	4,500	35	13	2.58	0.0408	109.0	98.2	47.6	49.2	71.9	39.1	3
1040	249	4,500	43	13	3.34	0.0544	116.0	104.6	50.8	57.2	72.0	40.1	3
1050	435	4,500	50	13	5.44	0.0680	137.8	123.6	60.3	66.7	81.6	44.7	3
1060	684	4,350	56	20	7.44	0.0862	147.0	130.0	63.5	76.2	97.9	52.3	3
1070	994	4,125	67	20	10.40	0.113	162.2	155.4	76.2	87.3	99.2	53.8	3
1080	2,050	3,600	80	27	17.90	0.172	193.0	180.8	88.9	104.8	118.4	64.5	3
1090	3,730	3,600	95	27	25.60	0.254	212.0	199.8	98.4	123.8	127.4	71.6	3
1100	6,280	2,440	110	42	42.00	0.426	250.7	246.2	120.6	142.1	156.6	-	5
1110	9,320	2,250	120	42	54.30	0.508	270.0	259.0	127.0	160.3	162.6	-	5
1120	13,700	2,025	140	61	81.20	0.735	306.4	304.4	149.2	179.4	191.7	-	6
1130	19,900	1,800	170	67	121.00	0.907	343.8	329.8	161.9	217.5	195.5	-	6
1140	28,600	1,650	200	67	178.00	1.130	383.8	374.4	184.2	254.0	201.7	-	6

T10 TYPE (SPLIT COVER - LARGE)

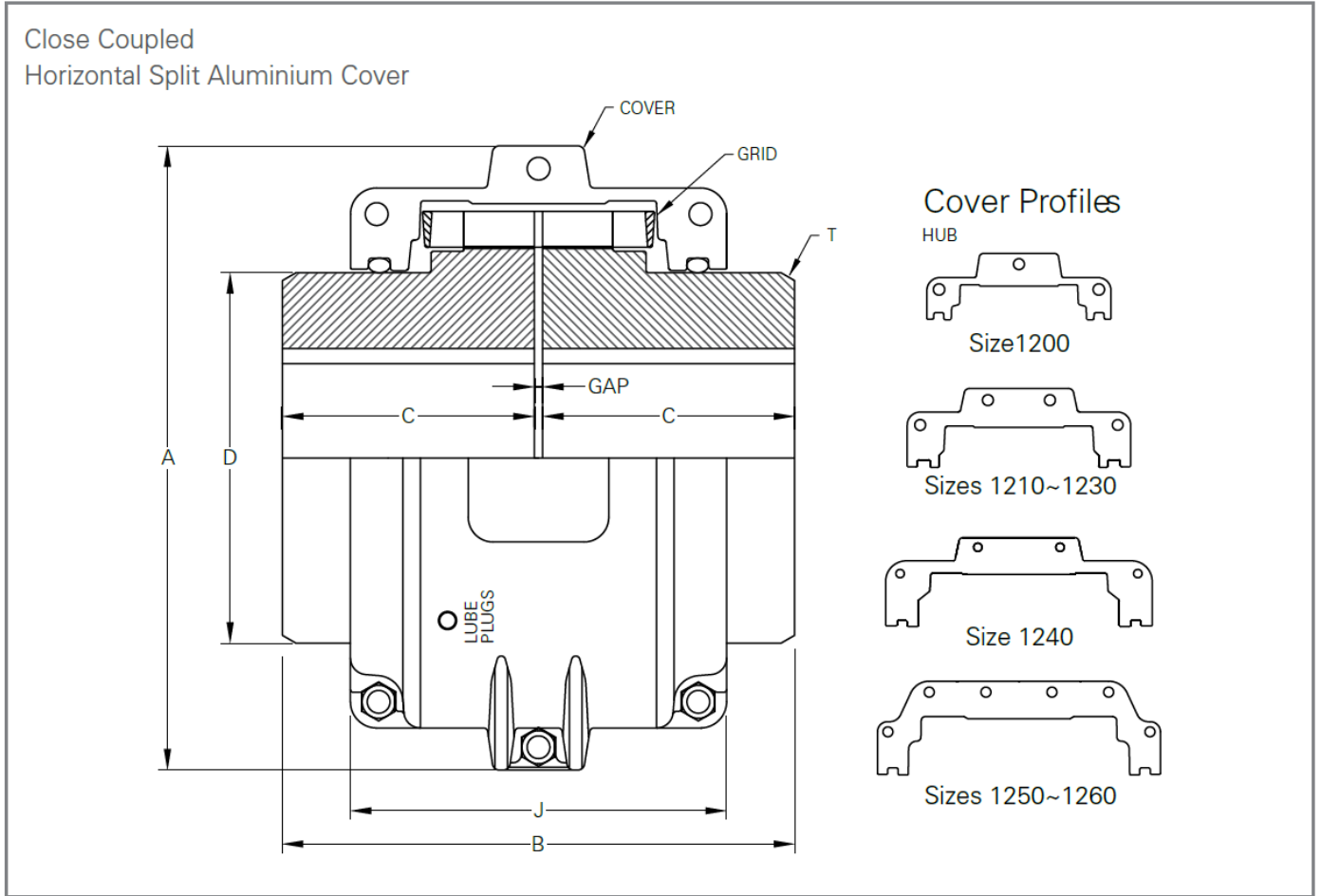

Size	Torque Rating (Nm)	Allow Speed RPM	Max Bore (mm)	Min Bore (mm)	Cplg Weight (Kg)	Lube Weight (Kg)	Dimensions (Millimeters)					
							A	B	C	D	J	GAP
1150	39,800	1,500	215	108	234	1.95	453.1	371.8	182.9	269.2	271.5	6
1160	55,900	1,350	240	121	317	2.81	501.9	402.2	198.1	304.8	278.4	6
1170	74,600	1,225	280	134	448	3.49	566.9	437.8	215.9	355.6	307.3	6
1180	103,000	1,100	300	153	619	3.76	629.9	483.6	238.8	393.7	321.1	6
1190	137,000	1,050	335	153	776	4.40	675.6	524.2	259.1	436.9	325.1	6
1200	186,000	900	360	178	1058	5.62	756.9	564.8	279.4	497.8	355.6	6
1210	249,000	820	390	178	1424	10.50	844.6	622.6	304.8	533.4	431.8	13
1220	336,000	730	420	203	1785	16.10	920.8	663.2	325.1	571.5	490.2	13
1230	435,000	680	450	203	2267	24.00	1,003.3	703.8	345.4	609.6	546.1	13
1240	559,000	630	480	254	2950	33.80	1,087.1	749.6	368.3	647.7	647.7	13
1250	746,000	580	-	254	3833	50.10	1,181.1	815.6	401.3	711.2	698.5	13
1260	932,000	540	-	254	4682	67.20	1,260.9	876.6	431.8	762.0	762.0	13

T20 TYPE (CLOSE COUPLED - VERTICAL STEEL COVER)

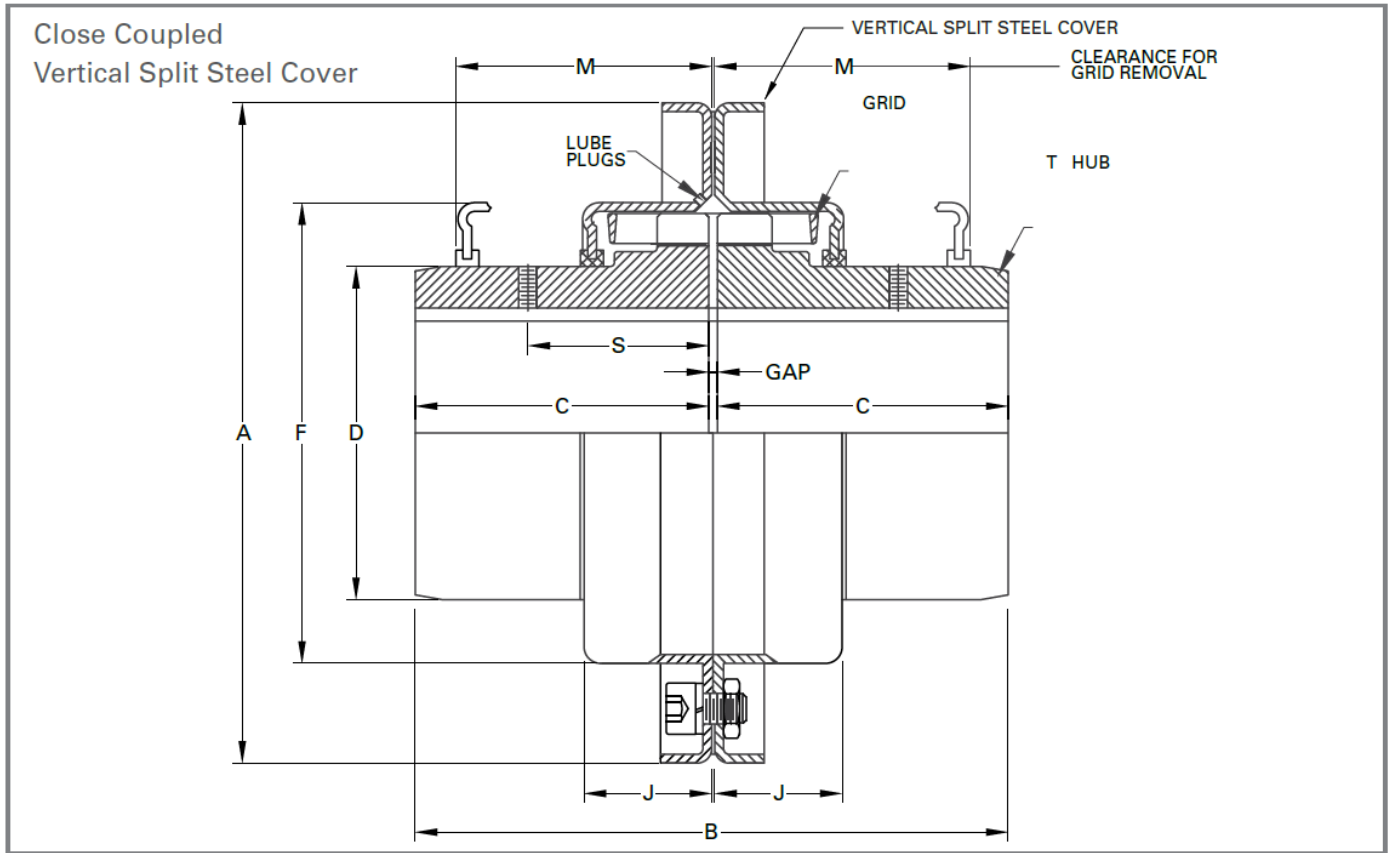

Size	Torque Rating (Nm)	Allow Speed RPM	Max Bore (mm)	Min Bore (mm)	Cplg Weight (Kg)	Lube Weight (Kg)	Dimensions (Millimeters)							
							A	B	C	D	F	J	M	GAP
1020	52	6,000	28	13	1.94	0.0272	112.3	98.2	47.6	39.7	64.3	23.9	47.8	3
1030	149	6,000	35	13	2.58	0.0408	121.8	98.2	47.6	49.2	73.8	24.9	47.8	3
1040	249	6,000	43	13	3.35	0.0544	129.8	104.6	50.8	57.2	81.8	25.9	50.8	3
1050	435	6,000	50	13	5.32	0.0680	148.8	123.6	60.3	66.7	97.6	30.5	60.5	3
1060	684	6,000	56	20	7.01	0.0862	163.1	130.0	63.5	76.2	111.1	31.8	63.5	3
1070	994	5,500	67	20	10.20	0.1130	174.2	155.4	76.2	87.3	122.3	33.5	66.5	3
1080	2,050	4,750	80	27	17.60	0.1720	201.2	180.8	88.9	104.8	149.2	43.7	88.9	3
1090	3,730	4,000	95	27	25.40	0.2540	232.9	199.8	98.4	123.8	168.3	47.0	95.2	3
1100	6,280	3,600	110	42	42.00	0.4260	267.9	246.2	120.6	142.1	198.0	59.7	120.7	5
1110	9,320	3,000	120	42	54.40	0.5080	286.9	259.0	127.0	160.3	216.3	62.7	124.0	5
1120	13,700	2,700	140	61	81.80	0.7350	320.2	304.4	149.2	179.4	245.5	73.7	142.7	6
1130	19,900	2,400	170	67	122.00	0.9070	379.0	329.8	161.9	217.5	283.8	74.9	146.0	6
1140	28,600	2,200	200	67	180.00	1.1300	417.1	374.4	184.2	254.0	321.9	78.2	155.4	6
1150	39,800	2,000	215	108	230.00	1.9500	476.2	371.8	182.9	269.2	374.4	107.3	203.2	6
1160	55,900	1,750	240	121	321.00	2.8100	533.4	402.2	198.1	304.8	423.9	115.3	215.9	6
1170	74,600	1,600	280	134	448.00	3.4900	584.2	437.8	215.9	355.6	474.7	120.1	226.1	6
1180	103,000	1,400	300	153	591.00	3.7600	630.0	483.6	238.8	393.7	546.0	130.0	-	6
1190	137,000	1,300	335	153	761.00	4.4000	685.0	524.2	259.1	436.9	589.0	135.0	-	6
1200	186,000	1,100	360	178	1021.00	5.6200	737.0	564.8	279.4	497.8	652.0	145.0	-	6

T31 TYPE (FULL SPACER)

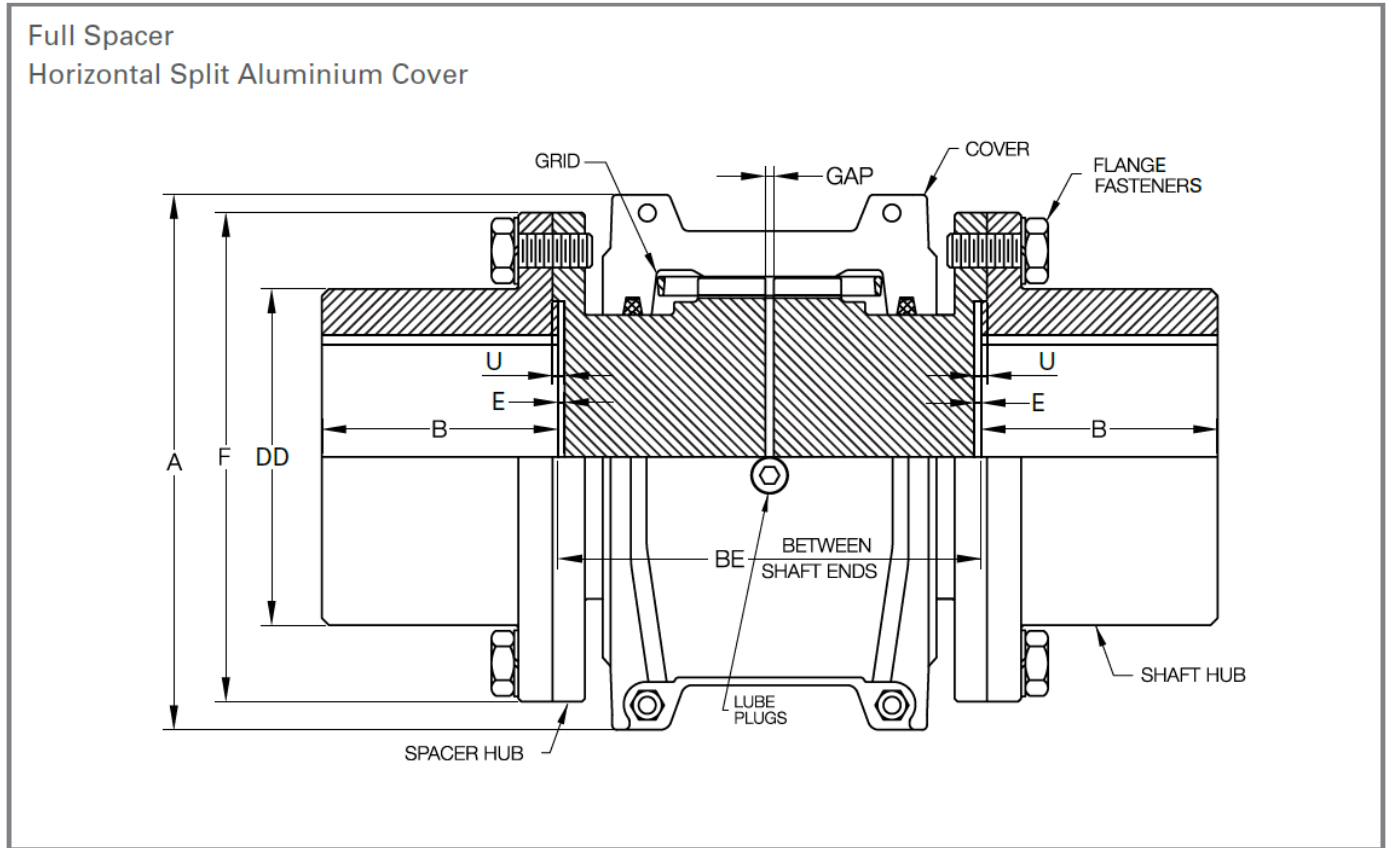

Size	Torque Rating (Nm)	Allow Speed RPM	Max Bore (mm)	Min Bore (mm)	Cplg Weight (Kg)	Add BE Weight (Kg)	Lube Weight (kg)	Dimensions (Millimeters)									Flange Fasteners	
								A	B	BE		DD	E	F	U	GAP	No. per Flange	Dia (mm)
										Min	Max							
1020	52	4,500	35	13	3.85	0.010	0.0272	101.0	34.9	88.9	203	52.4	0.8	85.7	1.8	5	4	6.3
1030	149	4,500	43	13	5.21	0.016	0.0408	109.0	41.3	88.9	216	59.5	0.8	93.7	1.8	5	8	6.3
1040	249	4,500	56	13	8.43	0.021	0.0544	116.0	54.0	88.9	216	78.6	0.8	112.7	1.8	5	8	6.3
1050	435	4,500	67	13	12.80	0.028	0.0680	137.8	60.3	111.1	216	87.3	0.8	125.4	1.8	5	8	7.9
1060	684	4,350	80	20	20.50	0.037	0.0862	147.0	73.0	122.2	330	103.2	1.8	144.5	2.8	5	8	9.5
1070	994	4,125	85	20	24.80	0.048	0.1130	162.2	79.4	127.0	330	109.5	1.8	152.4	2.8	5	12	9.5
1080	2,050	3,600	95	27	40.00	0.069	0.1720	193.0	88.9	155.5	406	122.2	1.8	177.8	2.8	5	12	12.7
1090	3,730	3,600	110	27	60.10	0.100	0.2540	212.0	101.6	163.5	406	142.9	1.8	209.6	2.8	5	12	15.8
1100	6,280	2,440	130	39	90.20	0.120	0.4260	250.7	90.4	203.2	406	171.4	1.6	250.8	3.2	6	12	19.0
1110	9,320	2,250	150	51	119.00	0.160	0.5080	270.0	104.1	209.6	406	196.8	1.6	276.2	3.2	6	12	19.0
1120	13,700	2,025	170	64	178.00	0.200	0.7350	306.4	119.4	246.1	406	225.4	1.6	319.1	4.0	10	12	22.2
1130	19,900	1,800	190	77	237.00	0.290	0.9070	343.8	134.6	257.1	406	238.1	1.6	346.1	4.0	10	12	25.4
1140	28,600	1,650	210	89	327.00	0.400	1.1300	383.8	152.4	266.7	406	266.7	1.6	385.8	4.0	10	12	28.5
1150	39,800	1,500	270	102	462.00	0.190	1.9500	453.1	172.7	344.5	371.3	334.3	5.1	425.4	-	10	14	22.2
1160	55,900	1,350	290	115	566.00	0.250	2.8100	501.4	186.4	355.6	406.4	366.0	6.6	457.2	-	10	14	22.2
1170	74,600	1,225	340	127	856.00	0.380	3.4900	566.4	220.2	384.2	444.5	424.9	8.4	527.0	-	10	16	25.4
1180	103,000	1,100	340	102	1,135.00	0.470	3.7600	629.9	248.9	400.1	490.5	450.8	5.1	590.6	8.1	10	16	28.5
1190	137,000	1,050	380	115	1,525.00	0.600	4.4000	675.6	275.8	411.2	530.4	508.0	5.1	660.4	8.1	10	18	31.7
1200	186,000	900	400	127	1,910.00	0.850	5.6200	756.9	305.3	444.5	574.5	530.4	6.1	711.2	9.1	10	18	31.7

T35 TYPE (HALF SPACER)

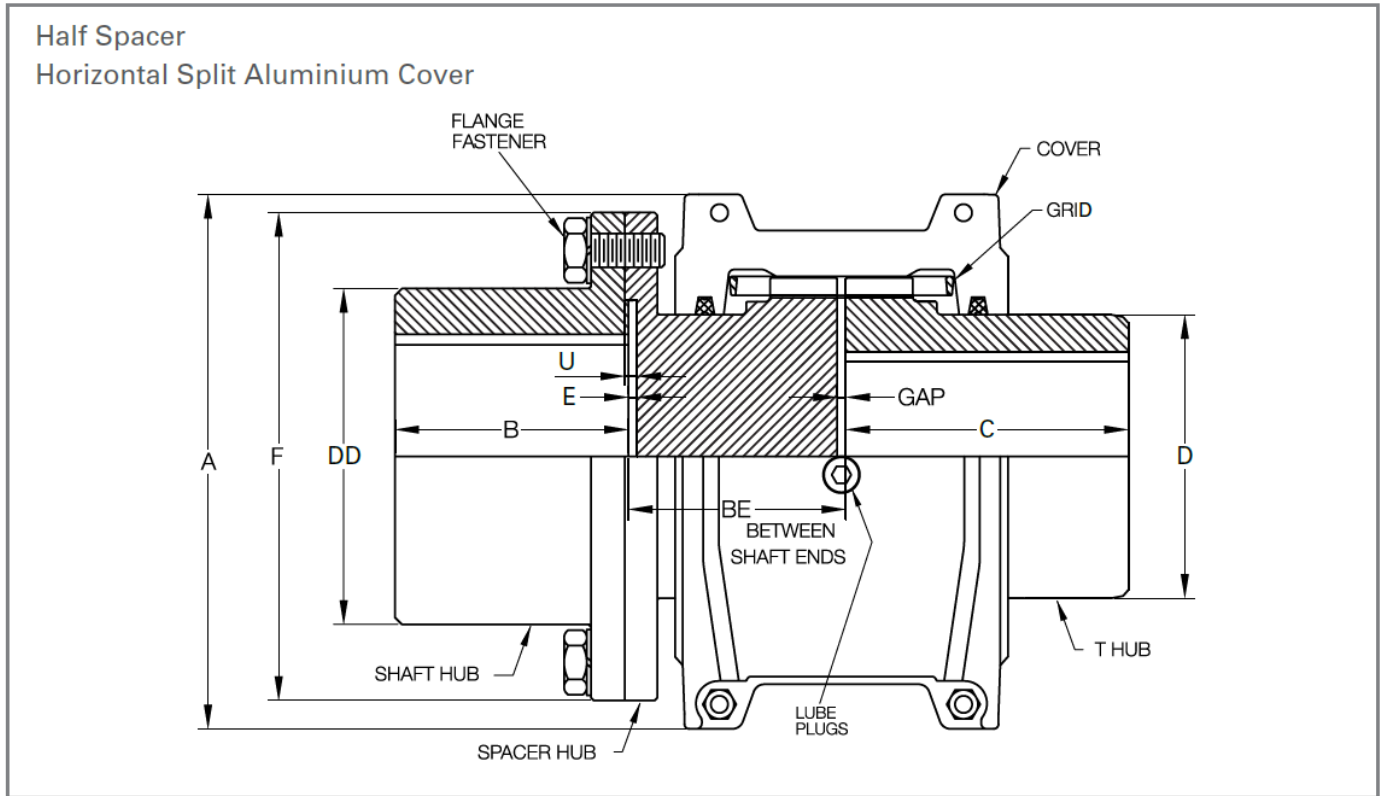

Size	Torque Rating (Nm)	Allow Speed RPM	Max Bore (mm)	Min Bore (mm)	Cplg Weight (Kg)	Add BE Weight (kg)	Lube Weight (Kg)	Dimensions (Millimeters)									Flange Fasteneres	
								A	B	BE		DD	E	F	U	GAP	No. per Flange	Dia (mm)
										Min	Max							
1020	52	4,500	35	13	3.85	0.010	0.0272	101.0	34.9	88.9	203	52.4	0.8	85.7	1.8	5	4	6.3
1030	149	4,500	43	13	5.21	0.016	0.0408	109.0	41.3	88.9	216	59.5	0.8	93.7	1.8	5	8	6.3
1040	249	4,500	56	13	8.43	0.021	0.0544	116.0	54.0	88.9	216	78.6	0.8	112.7	1.8	5	8	6.3
1050	435	4,500	67	13	12.80	0.028	0.0680	137.8	60.3	111.1	216	87.3	0.8	125.4	1.8	5	8	7.9
1060	684	4,350	80	20	20.50	0.037	0.0862	147.0	73.0	122.2	330	103.2	1.8	144.5	2.8	5	8	9.5
1070	994	4,125	85	20	24.80	0.048	0.1130	162.2	79.4	127.0	330	109.5	1.8	152.4	2.8	5	12	9.5
1080	2,050	3,600	95	27	40.00	0.069	0.1720	193.0	88.9	155.5	406	122.2	1.8	177.8	2.8	5	12	12.7
1090	3,730	3,600	110	27	60.10	0.100	0.2540	212.0	101.6	163.5	406	142.9	1.8	209.6	2.8	5	12	15.8
1100	6,280	2,440	130	39	90.20	0.120	0.4260	250.7	90.4	203.2	406	171.4	1.6	250.8	3.2	6	12	19.0
1110	9,320	2,250	150	51	119.00	0.160	0.5080	270.0	104.1	209.6	406	196.8	1.6	276.2	3.2	6	12	19.0
1120	13,700	2,025	170	64	178.00	0.200	0.7350	306.4	119.4	246.1	406	225.4	1.6	319.1	4.0	10	12	22.2
1130	19,900	1,800	190	77	237.00	0.290	0.9070	343.8	134.6	257.1	406	238.1	1.6	346.1	4.0	10	12	25.4
1140	28,600	1,650	210	89	327.00	0.400	1.1300	383.8	152.4	266.7	406	266.7	1.6	385.8	4.0	10	12	28.5
1150	39,800	1,500	270	102	462.00	0.190	1.9500	453.1	172.7	344.5	371.3	334.3	5.1	425.4	-	10	14	22.2
1160	55,900	1,350	290	115	566.00	0.250	2.8100	501.4	186.4	355.6	406.4	366.0	6.6	457.2	-	10	14	22.2
1170	74,600	1,225	340	127	856.00	0.380	3.4900	566.4	220.2	384.2	444.5	424.9	8.4	527.0	-	10	16	25.4
1180	103,000	1,100	340	102	1,135.00	0.470	3.7600	629.9	248.9	400.1	490.5	450.8	5.1	590.6	8.1	10	16	28.5
1190	137,000	1,050	380	115	1,525.00	0.600	4.4000	675.6	275.8	411.2	530.4	508.0	5.1	660.4	8.1	10	18	31.7
1200	186,000	900	400	127	1,910.00	0.850	5.6200	756.9	305.3	444.5	574.5	530.4	6.1	711.2	9.1	10	18	31.7

T50 TYPE (FLOATING SHAFT – STEEL COVER)

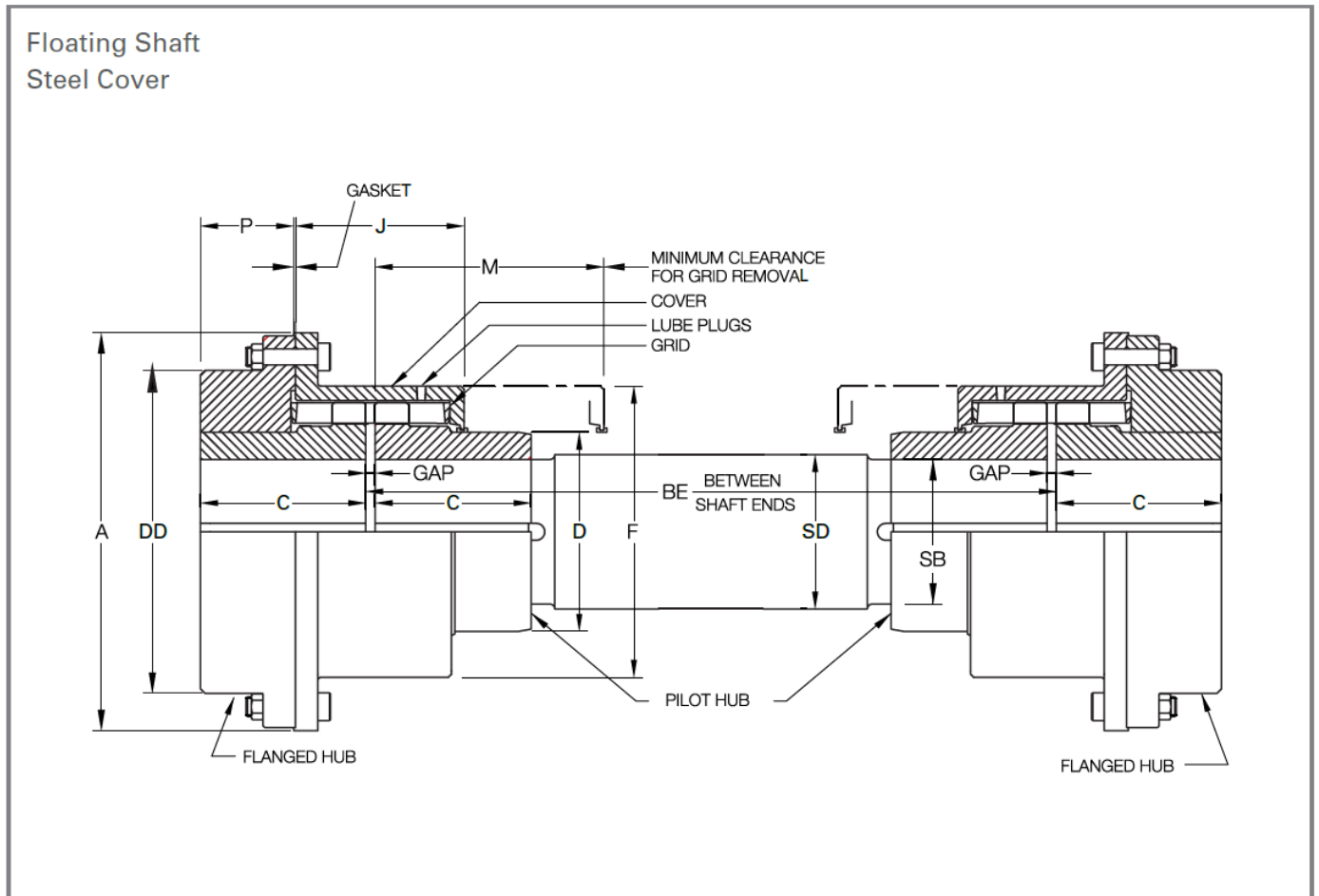

Size	Torque Rating (Nm)	Max Bore (mm)		Min Bore (mm)	Cplg Weight (Kg)	Lube Weight (Kg)	Dimensions (Millimeters)											
		Flanged Hub	Pilot Hub				A	BE Min	C	D	DD	F	J	M	P	SB	SD	GAP
1030	149	35	27.0	13	3.90	0.0408	115.9	162	47.6	49.2	83.7	80.8	50.3	77.7	26.8	27.0	28.6	3
1050	435	50	36.5	13	8.84	0.0680	157.5	195	60.3	66.7	105.2	104.8	59.2	94.0	36.2	36.5	38.1	3
1070	994	67	49.2	20	15.60	0.1130	182.9	213	76.2	87.3	126.5	129.0	65.9	103.1	49.8	49.2	50.8	3
1080	2,050	80	61.9	27	26.40	0.1720	218.4	275	88.9	104.8	154.9	156.2	85.9	134.1	52.1	61.9	63.5	3
1090	3,730	95	74.6	27	37.20	0.2540	244.9	294	98.4	123.8	180.3	175.8	92.2	143.8	58.5	74.6	76.2	3
1100	6,280	110	92.1	42	62.80	0.4260	286.0	372	120.6	142.1	211.3	208.3	117.3	181.4	69.3	92.1	95.2	5
1110	9,320	120	101.6	42	83.60	0.5080	324.1	391	127.0	160.3	245.4	228.6	122.2	190.5	73.9	101.6	104.8	5
1120	13,700	140	117.5	61	97.90	0.7350	327.2	453	149.2	179.4	179.3	257.0	146.3	220.0	83.6	117.5	120.6	6
1130	19,900	170	133.4	67	140.00	0.9070	365.3	463	161.9	217.5	217.4	295.1	149.5	225.0	94.8	133.4	136.5	6
1140	28,600	200	142.9	67	210.00	1.1300	419.1	482	184.2	254.0	254.0	335.8	155.8	234.7	113.8	142.9	146.0	6
1150	39,800	215	161.9	108	277.00	1.9500	477.5	549	182.9	271.4	269.2	391.2	177.4	268.2	101.7	161.9	165.1	6
1160	55,900	240	200.0	121	381.00	2.8100	548.6	587	198.1	304.8	304.8	442.0	189.4	287.0	111.9	200.0	203.2	6
1170	74,600	280	200.0	134	519.00	3.4900	604.5	622	215.9	355.6	355.6	494.3	201.0	304.8	124.6	200.0	203.2	6
1180	103,000	300	225.4	153	718.00	3.7600	665.5	673	238.8	393.7	393.7	556.3	226.9	330.2	141.4	225.4	228.6	6
1190	137,000	335	250.8	153	898.00	4.4000	708.7	711	259.1	436.9	436.9	599.4	241.7	349.5	157.6	250.8	254.0	6
1200	186,000	360	276.2	178	1,205.00	5.6200	782.3	744	279.4	497.8	497.8	622.9	251.8	365.8	172.8	276.2	279.4	6

T63 TYPE (DISC BRAKE)

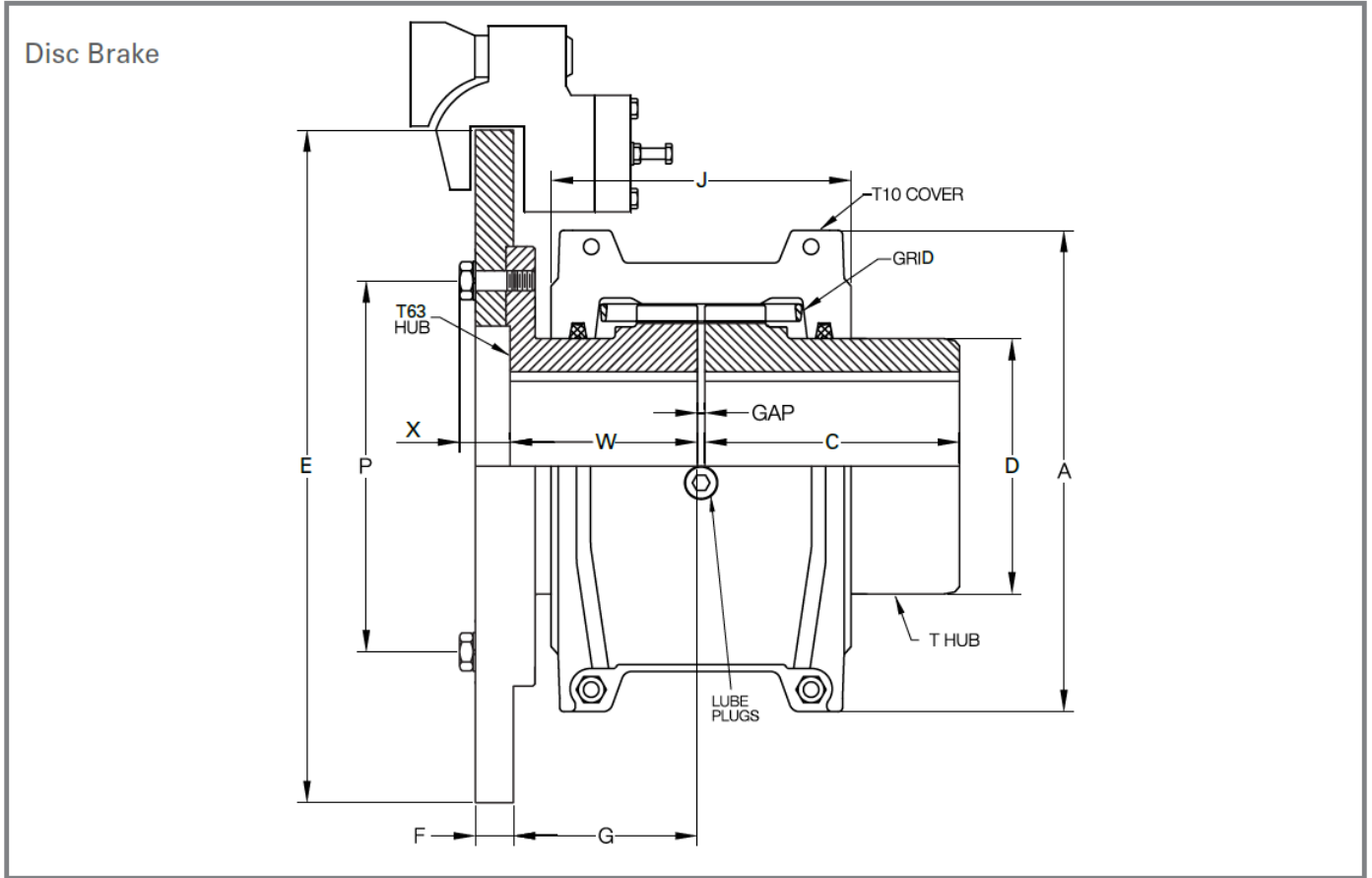

Size	Brake Rating (Nm)	Allow Speed RPM	Max Bore (mm)	Min Bore (mm)	Cplg Weight (Kg)	Lube Weight (kg)	Dimensions (Millimeters)									Disc Brake Dia x Thickness (ExF)
							A	C	D	G	J	P	W	X	GAP	
1020	11	4,500	28	13	2.55	0.0272	97.0	47.6	39.7	59.9	67.8	71.4	60.5	11.7	3	
1030	35	4,500	35	13	3.31	0.0408	105.7	47.6	49.2	59.9	71.9	79.4	60.5	11.7	3	
1040	65	4,500	43	13	4.26	0.0544	114.3	50.8	57.2	59.9	72.0	98.4	60.5	11.7	3	
1050	118	4,150	50	13	6.35	0.0680	135.1	60.3	66.7	59.9	81.6	108.0	60.5	13.2	3	
1060	209	3,800	56	20	9.57	0.0862	147.8	63.5	76.2	88.6	97.9	125.4	88.1	15.2	3	
1070	331	3,250	67	20	12.30	0.1130	158.8	76.2	87.3	88.6	99.2	133.4	88.1	15.2	3	
1080	637	2,850	80	27	19.80	0.1720	190.5	88.9	104.8	88.6	118.4	152.4	88.1	18.0	3	
1090	1,084	2,700	95	27	28.40	0.2540	211.1	98.4	123.8	87.9	127.4	179.4	88.1	26.9	3	
1100	1,897	2,400	110	42	47.70	0.4260	251.0	120.6	142.1	119.1	156.6	215.9	119.1	29.5	5	
1110	2,846	2,250	120	42	64.90	0.5080	269.7	127.0	160.3	146.0	162.6	241.3	146.0	29.5	5	
1120	4,336	2,025	140	61	92.10	0.7350	307.8	149.2	179.4	150.1	191.7	276.2	149.4	33.0	6	
1130	6,098	1,800	170	67	132.0	0.9070	345.9	161.9	217.5	153.4	195.5	295.3	152.4	35.6	6	
1140	8,808	1,650	200	67	185.0	1.1300	384.0	184.2	254.0	159.8	201.7	330.2	158.8	38.1	6	
1150	12,195	1,500	215	108	253.0	1.9500	453.1	182.9	269.2	179.8	271.5	368.3	182.9	31.5	6	
1160T	16,938	1,350	240	121	336.0	2.8100	501.9	198.1	304.8	195.1	278.4	400.0	198.1	31.5	6	

KBW TYPE (DRUM BRAKE)

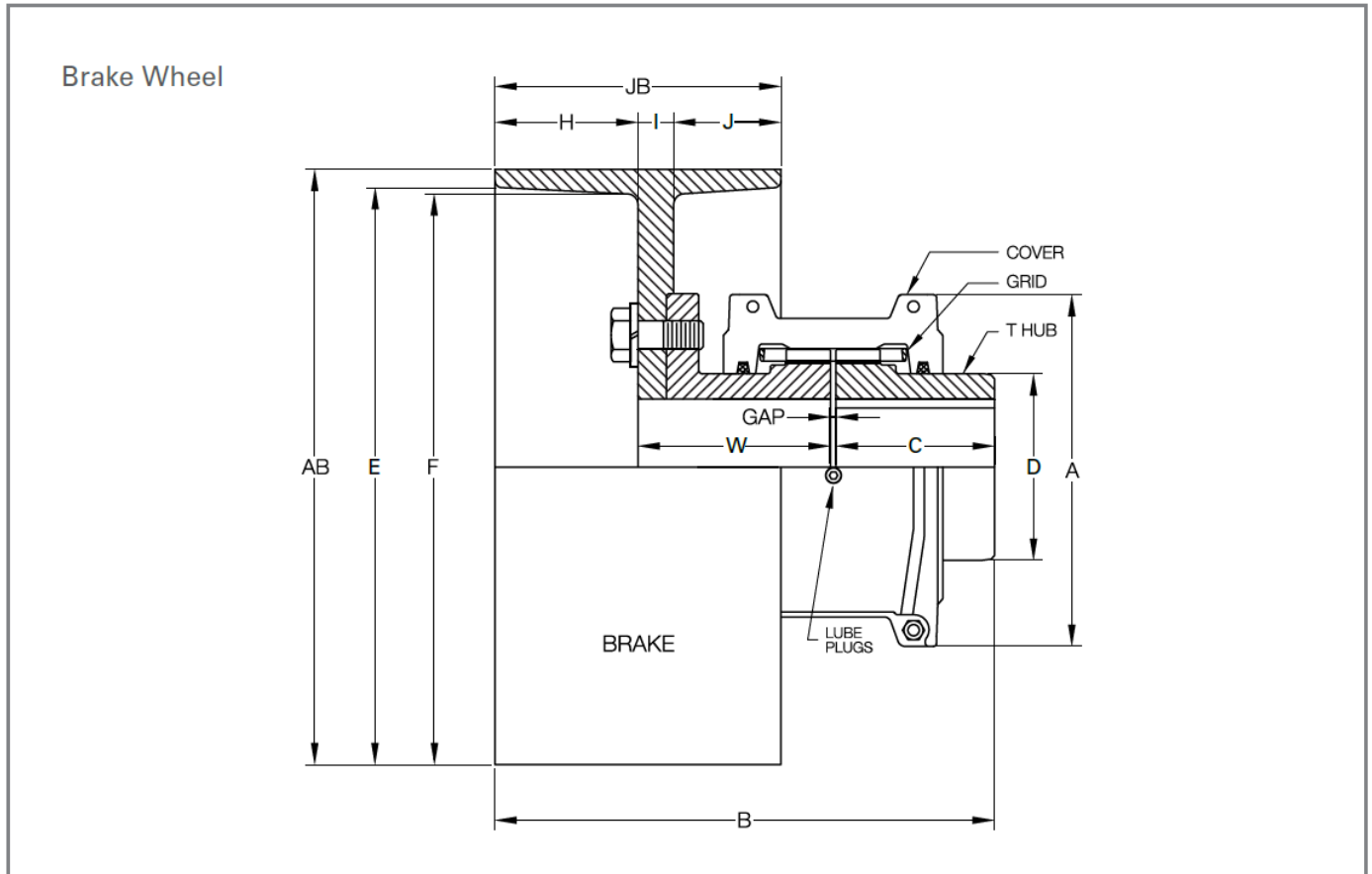

Size	Brake Rating (Nm)	Max Bore (mm)	Min Bore (mm)	Lube Weight (kg)	Dimensions (Millimeters)									Brake Wheel Size	
					A	C	D	E	F	H	I	J	GAP	AB (mm)	JB (mm)
1020	10.78	30	12.7	0.03	101.0	47.6	39.7	-	-	-	-	-	3	-	-
1030	35.18	36	12.7	0.03	109.0	47.6	49.2	-	-	-	-	-	3	-	-
1040	64.97	44	12.7	0.05	116.0	50.8	57.2	145.0	140.0	40.0	12.0	28.0	3	160	80
1050	117.80	50	12.7	0.05	137.8	60.3	66.7	184.0	178.0	50.0	17.0	33.0	3	200	100
1060	208.64	57	19.1	0.09	147.0	63.5	76.2	184.0	178.0	50.0	17.0	33.0	3	200	100
1070	330.55	68	19.1	0.11	162.2	76.2	87.3	230.0	224.0	62.5	22.0	40.5	3	250	125
1080	636.71	82	27.0	0.17	193.0	88.9	104.8	292.0	285.0	80.0	23.0	57.0	3	315	160
1090	1,083.88	95	27.0	0.25	212.0	98.4	123.8	330.0	320.0	90.0	26.0	64.0	3	355	180
1100	1,896.79	107	41.3	0.43	250.7	120.6	142.1	374.0	362.0	100.0	28.0	72.0	5	400	200
1110	2,845.14	117	41.3	0.51	270.0	127.0	160.3	422.0	410.0	112.0	32.0	80.0	5	450	224
1120	4,335.52	136	60.3	0.73	306.4	149.2	179.4	462.0	445.0	125.0	35.0	90.0	6	500	250
1130	6,488.78	165	66.7	0.91	343.8	161.9	217.5	516.0	495.0	140.0	45.0	95.0	6	560	280
1140T	8,806.48	184	66.7	1.13	383.8	184.2	254.0	516.0	495.0	140.0	45.0	95.0	6	560	280

T10 / G82 TYPE (FLOATING SHAFT)

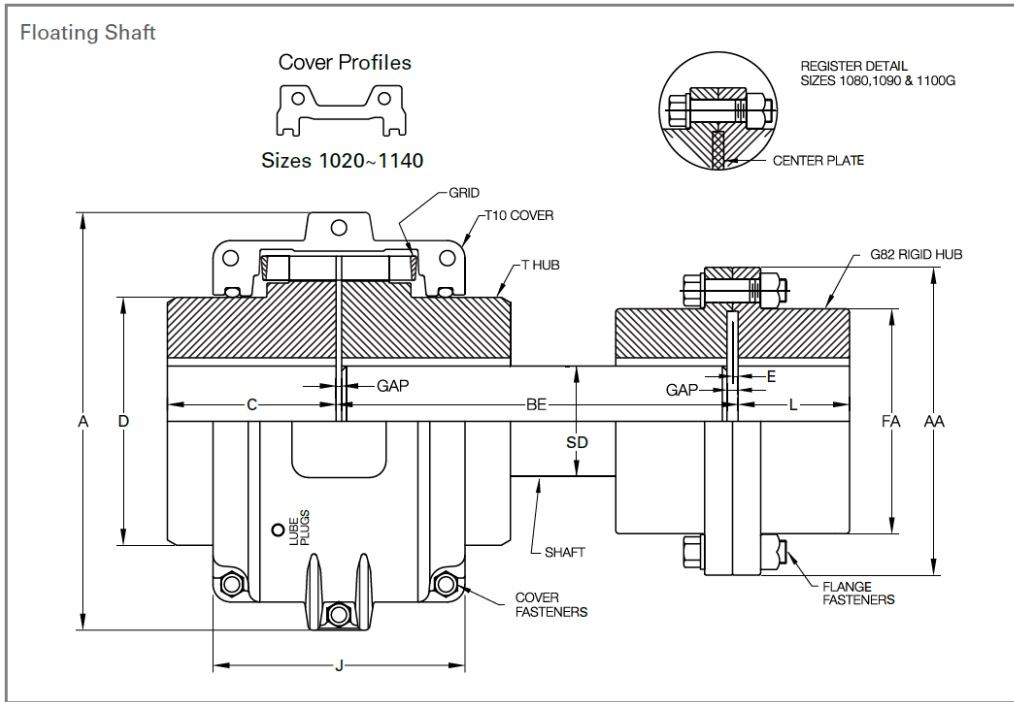

T10Cplg Size	G82 Cplg Size	Torque Rating (Nm)	Allow Sped RPM	Max Bore (mm)		Min Bore (mm)		Cplg Weight (Kg)	Add BE Weight (Kg)	Lube Weight (Kg)	Fasteners	
				T10 Hub (mm)	G82 Hub (mm)	T10 Hub (mm)	G82 Hub (mm)				No. per Flange	Dia (mm)
1110	1035	9,320	2,250	120	164	42	51	125	0.0804	0.508	8	0.750
1120	1040	13,700	2,025	140	196	61	64	183	0.0992	0.735	8	0.750
1130	1045	19,900	1,800	170	216	67	76	261	0.1430	0.907	10	0.750
1140	1050	28,600	1,650	200	242	67	89	382	0.2090	1.130	8	0.875
1150	1055	39,800	1,500	215	267	108	102	508	0.2540	1.950	14	0.875
1160	1060	55,900	1,350	240	293	121	115	645	0.3220	2.810	14	0.875
1170	1070	74,600	1,225	280	341	134	127	983	0.3970	3.490	16	1.000
1180	1080	103,000	1,100	300	341	153	102	1313	0.4800	3.760	16	1.125
1190	1,090	137,000	1,050	335	380	153	115	1756	0.5720	4.400	18	1.250
1200	1100	186,000	900	360	405	178	127	2254	0.6710	5.620	18	1.250

T10 Cplg Size	G82 Cplg Size	Dimensions (mm)											GAP	
		A	BE		C	D	E	J	L	AA	FA	SD	T Hub	G82 Hub
			Min	Max										
1110	1035	269.7	239.0	304.8	127.0	160.3	2.5	161.5	102.1	279.4	211.3	114.3	5	5
1120	1040	307.8	279.1	355.6	149.2	179.4	4.1	191.5	115.3	317.5	245.4	127.0	6	8
1130	1045	345.9	307.1	381.0	161.9	217.5	4.1	195.1	130.6	345.9	274.1	152.4	6	8
1140	1050	384.0	348.0	406.4	184.2	254.0	5.1	201.2	147.3	388.9	305.8	184.2	6	10
1150	1055	453.1	372.1	406.4	182.9	269.2	5.1	271.5	172.7	425.4	334.3	203.2	6	10
1160	1060	501.9	404.1	457.2	198.1	304.8	6.6	278.4	186.4	457.2	366.0	228.6	6	13
1170	1070	566.9	459.2	508.0	215.9	355.6	8.4	307.3	220.2	527.0	424.9	254.0	6	17
1180	1080	629.9	510.3	660.4	238.8	393.7	8.1	321.1	248.9	590.6	450.8	279.4	6	16
1190	1090	675.6	557.5	711.2	259.1	436.9	8.1	325.1	275.8	660.4	508.0	304.8	6	16
1200	1100	756.9	609.3	762.0	279.4	497.8	9.1	355.6	305.3	711.2	530.4	330.2	6	18

INSTALLATION

Requirements are wrenches, a straight edge and feeler gauges to install the couplings. Its size from 1020 to 1090 are furnished for a clearance fit with a setscrew over the keyway. Larger sizes (from 1100 and up) are furnished for an interference fit without a setscrew.

Clearance Fit Hubs: Clean all parts using a non-

1) Mount Seals and Hubs

Lock out starting switch of prime mover. Clean metal parts using a non-flammable solvent. Lightly coat seals with grease and place on shafts before mounting hubs. Heat interference fit hubs. Seal keyways to prevent leakage. Mount hubs on their corresponding shafts so that the hub face is flush with the end of the shaft (unless otherwise indicated).

2) Gap and Alignment

Use a spacer bar which is equal in thickness to the gap between shafts. Insert bar and same depth at 90° intervals and measure clearance between bar and hub face with feelers. The difference in minimum and maximum measurements must not exceed the angular installation limits.

3) Offset Alignment

Align a straight edge so that it rests squarely on both hubs as shown in the diagram. Check with feelers. The clearance must not exceed the parallel offset installation limits. Tighten all foundation bolts and repeat Steps 2 and 3. Realign coupling if necessary.

4) Insert Grid

Pack the gap and grooves with specified lubricant before inserting grid. When grids are furnished in two or more segments, install them so that all cut ends extend in the same direction. This will assure correct contact between the grid and any nonrotating pins in each half of the covers.

flammable solvent. Check hubs, shafts and keyways for burrs. Install keys. Mount hubs with the flange face flush with shaft ends (or as otherwise specified). Tighten setscrews. Do not heat clearance fit hubs.

Interference Fit Hubs: Furnished without setscrews.

Spread the grid just enough so that it passes over the coupling teeth. Seal with a soft mallet.

5) Pack

Pack any spaces between and around the grid with as much lubricant as possible. Wipe off any excess so that any remaining lubricant is flush with top of grid. Position hub seals to line up with the grooves in the cover. Position gaskets on lower cover half flange and assemble the two covers so that the match marks are on the same side. If shafts are not horizontally level, or if the coupling is to be used vertically, assemble cover halves with the lug so that the match marks are up or are on the high side. Push gaskets in against the seals as far as possible. Secure cover halves with fasteners and tighten to torque. Make sure gaskets stay in position while the fasteners are tightened.

Annual Maintenance

- Check alignment. If the maximum operating misalignment limits exceeded, realign the coupling to the recommended installation limits.
- Check that all fasteners are tightened to torque.
- Inspect Oil Seal and Gasket to determine if replacement is required. Replace if the Seal and gasket are leaking grease.
- Disassemble the coupling and inspect for wear. Replace any worn parts. Clean grease from coupling and repack with new grease. Install coupling using a new gasket.

VIBRATION & SHOCK

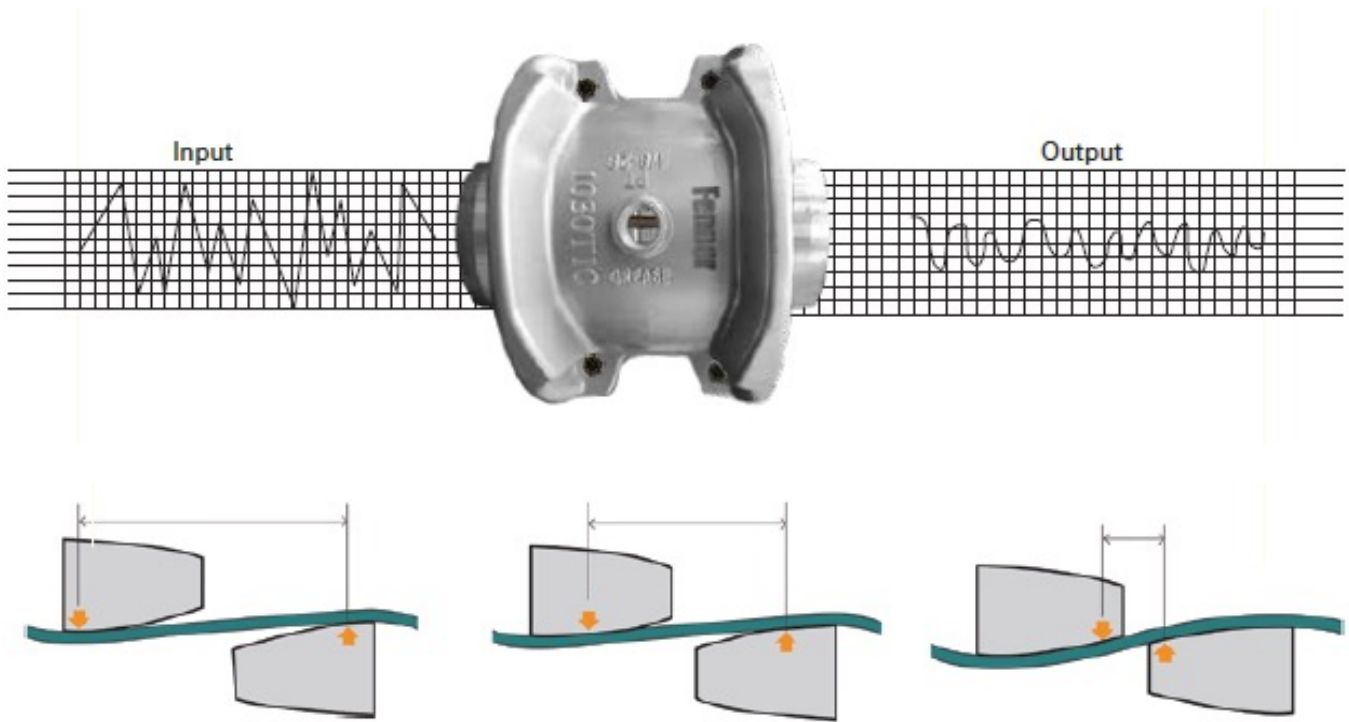

NORMAL LOAD

As the load increases, the distance between the contact points on the hub teeth is shortened, but a free span still remains to cushion the load.

LIGHT LOAD

The grid contacts near the outer edges of the hub teeth. A long span between the points of contact remains free to flex under load.

SHOCK LOAD

The coupling is flexible within its rated capacity. Under extreme overloads, the grid bears fully on the hub teeth and transmits full load directly.

LUBRICATION

- Grease the Grid & Hub teeth before assembling covers.
- Fill up grease through the lubricants plug of the assembled coupling.
- Select grease according to the ambient temperature range.
- Replenish grease every three months or 240-250 hours of operation.
- Replace deteriorated grease every three years or 4,000 operating hours.

Grease: Shell Gadus S3 High Speed Coupling Grease or Shell Gadus S2 V220 1

ALIGNMENT DATA

Accurate alignment results to maximum life and minimum maintenance for the coupling and the connected machinery. The amount of time for a coupling to reach its maximum operating limits is a function of load, operating speed, and lubrication. Maximum operating values listed in the table below are based on the allowable RPM listed on the catalogue. Values listed are based on the use of the specified gaps, use of standard coupling components, standard assemblies, and catalogue allowable speeds. Values may be combined for installation or operating condition. Parallel misalignment is the distance between the centres of each shaft. Angular misalignment is dimension X minus dimension Y as shown in the drawing below. End float is the axial movement of the hubs within the covers as measured from "0" gap. This measure assumes zero angular and zero parallel misalignment.

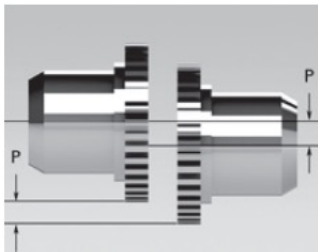

Parallel Misalign-

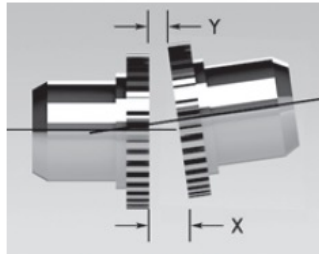

Angular Misalign-

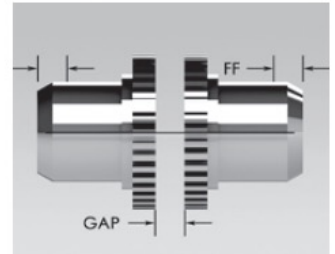

End Float

Fenner Grid Coupling

MISALIGNMENT CAPACITY

Size	Recommended Installation			Operating			Fastener Tightening Torque Rating (Nm)
	Parallel Offset-P Max (mm)	Angular (X-Y) Max (mm)	Hub Gap (10%) Max (mm)	Parallel Offset-P Max (mm)	Angular (X - Y) Max (mm)	End Float (2 x F) Max (mm)	
1020	0.15	0.08	3	0.30	0.25	5.33	11.30
1040	0.15	0.08	3	0.30	0.33	5.36	11.30
1060	0.20	0.13	3	0.41	0.46	6.55	22.60
1080	0.20	0.15	3	0.41	0.61	7.32	22.60
1100	0.25	0.20	3	0.51	0.84	10.90	35.00
1120	0.28	0.25	5	0.56	1.02	14.12	73.00
1140	0.28	0.33	6	0.56	1.35	14.50	73.00
1160	0.30	0.46	6	0.60	1.78	-	-
1180	0.38	0.56	6	0.76	2.26	-	-
1200	0.38	0.69	6	0.76	2.72	-	-
1220	0.46	0.81	13	0.91	3.28	-	-
1240	0.48	0.97	13	0.97	3.91	-	-
1260	0.51	1.17	13	1.02	4.65	-	-

Fenner Grid Coupling

PULLER HOLES

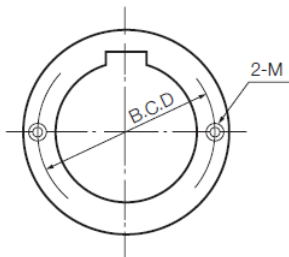

Size	B.C.D (mm)	Tap Size	Size	B.C.D (mm)	Tap Size
1150	263	M16 x 2.0 x 24	1210	497	M36 x 4.0 x 45
1160	298	M22 x 2.5 x 27	1220	541	M36 x 4.0 x 45
1170	338	M30 x 3.5 x 32	1230	586	M36 x 4.0 x 45
1180	378	M30 x 3.5 x 38	1240	633	M36 x 4.0 x 45
1190	413	M36 x 4.0 x 45	1250	690	M36 x 4.0 x 45
1200	456	M36 x 4.0 x 45	1260	749	M36 x 4.0 x 45



iMOTION®

Delivering a world-class customer-first approach providing excellence and expertise in industrial products, solutions and services.

iMOTION
FLUID POWER SOLUTIONS

Integrated solutions by specialists in fluid power, hydraulic, pneumatic and flow technologies.

iMOTION
ENGINEERING & SERVICES

Specialist design and engineering, manufacturing, repair and maintenance services.

Anytime.Anywhere.
Always Here.™



Find a location near you!

Scan the QR Code to find out more
or visit [Motion.com.au](https://www.motion.com.au)